

# EL20



## SPECIFICATIONS

### ACOUSTIC & ELECTRICAL SPECIFICATIONS:

- \* Nominal Impedance: 8 ohm
- \* Recommended Amp Power: 15-100W
- \* Frequency Response: 60 Hz - 20 kHz ( $\pm 3$ dB)
- \* Sensitivity: 90 dB / 2,83V / 1 m
- \* Crossover frequency: 600HZ / 3 kHz

### SYSTEM COMPONENTS:

- \* Cabinet: CEL20 (Not for sale)
- \* Grille: GEL20 (2408550)
- \* Woofer: HT210JL16 210mm Woofer  
25mm voice coil
- DC Resistance: 6 ohm
- \* Midrange: HT110JL10 110mm Midrange  
25mm voice coil

### SYSTEM COMPONENTS: (cont'd)

- DC Resistance: 4,2 ohm
- \* Tweeter: TW010IY3 10mm  
Dome Tweeter
- DC Resistance: 5,5 ohm
- \* Crossover Network: NEL20 (2708550)

### PHYSICAL SPECIFICATIONS:

- \* Enclosure Dimensions (H.W.D): 20,5x9,7x11,6 in. D  
(520x246x295mm D)
- \* Shipping Weight: 24 lbs. (11 kg.)

### WARRANTY INFORMATION:

- \* Refer to the Warranty Statement packed with each product

## PACKAGE

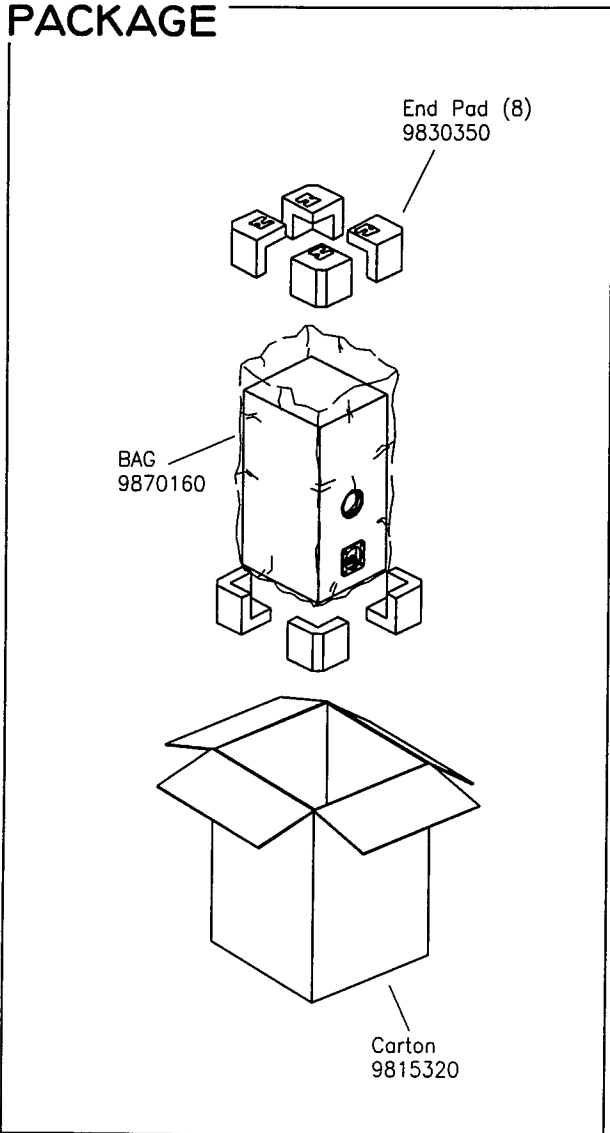

## WIRING DIAGRAM

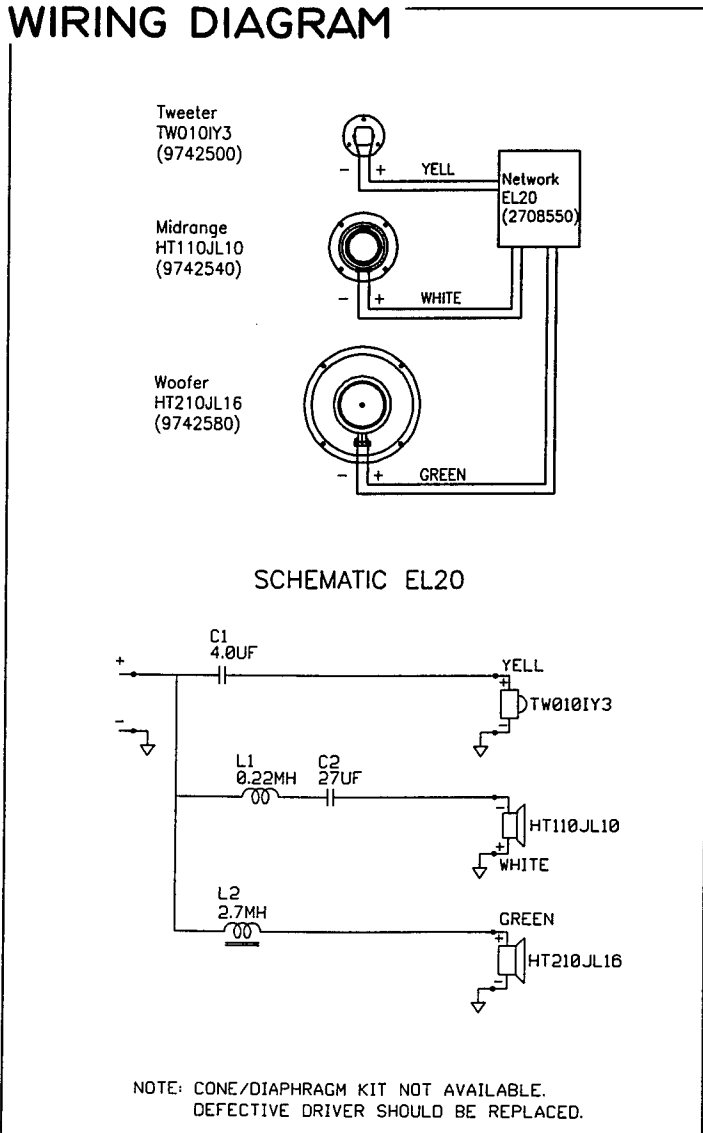

EL20

Valid from serial no. 01001  
Rev. 28/3-1996

## COMPONENT EXPLODED VIEW

